



MSX MODULE INSTALLATION USER MANUAL

VERSION: 1
VERSION DATE: 6/10/2025

DOCUMENT #: P-UM-0014
PAGE: 1 OF 15



Module Types
MSX10-xxxHN0B





MSX MODULE INSTALLATION USER MANUAL

VERSION: 1

VERSION DATE: 6/10/2025

DOCUMENT #: P-UM-0014

PAGE: 2 OF 15

1.0 INTRODUCTION	3
2.0 DISCLAIMER OF LIABILITY	3
3.0 GENERAL INFORMATION	3
3.1 General Safety -4	
4.0 WARNING & NOTICES	5
5.0 INSTALLATION & OPERATION	7
5.1 Mechanical Installation -7	
5.2 Roof Mount - 8	
5.3 Fire Rating - 9	
5.4 Grounding - 9	
5.5 Air Circulation Under Module - 10	
5.6 Electrical Installation -10	
5.7 Modules and Termination - 11	
6.0 MAINTENACE, TESTING & TROUBLESHOOTING.....	12
6.1 Maintenance - 12	
6.2 System Test and Troubleshooting - 12	
7.0 SPECIFICATIONS	13
7.1 Physical Specifications -13	
7.2 Electrical Specifications - 14	
7.3 Temperature Coefficient - 14	
7.4 Junction Box Specifications - 15	
7.5 Bypass Diode Specifications - 15	
7.6 Frame Schematics - 15	
8.0 WARRANTY	15



MSX MODULE INSTALLATION USER MANUAL

VERSION: 1

VERSION DATE: 6/10/2025

DOCUMENT #: P-UM-0014

PAGE: 3 OF 15

1.0 INTRODUCTION

This Guide contains application and safety information with which you should be familiar before using your Mission Solar Energy, LLC. ("Mission Solar Energy") PV module. Your authorized Mission Solar Energy distributor or dealer can provide additional sizing and system design information if necessary.

2.0 DISCLAIMER OF LIABILITY

Since the use of this guide and the conditions or methods of installation, operation, use, and maintenance of the module are beyond Mission Solar Energy control, Mission Solar Energy does not assume responsibility and expressly disclaims liability for loss, damage, or expense arising out of or in any way connected with such installation, operation, use, or maintenance. Mission Solar assumes no responsibility for any infringement of patents or other rights of third parties that may result from use of the module.

No license is granted by implication or otherwise under any patent or patent rights. The information in this guide is based on Mission Solar Energy knowledge and experience and is believed to be reliable; but such information including product specifications (without limitations) and suggestions do not constitute a warranty, expressed or implied. Mission Solar reserves the right to make changes to the product, specifications, or guide without prior notice.

3.0 GENERAL INFORMATION

The installation of modules requires a great degree of skill and should (if DC voltage exceeds 100 V) must only be performed by a qualified licensed professional, including, without limitation, licensed contractors, and licensed electricians. The installer assumes the risk of all injury that might occur during installation, including, without limitation, the risk of electric shock. Mission Solar modules do not require the use of special cable assemblies. All modules come with a permanently attached junction box that will accept a variety of wiring applications or with a special cable assembly for ease of installation.



WARNING!

IT IS RECOMMENDED TO UTILIZE A QUALIFIED INSTALLER OR RESELLER FOR SERVICE.

All instructions should be read and understood before attempting to install, wire, operate, and maintain the Module. Contact with electrically active parts of the module such as terminals can result in burns and lethal shock whether the module is connected or disconnected.

Modules produce electricity when sunlight or other sources illuminate the front side (or back side for bi-facial modules). The voltage from a single module is not considered a shock hazard. When modules are connected in series, voltages are additive. When modules are connected in parallel, current is additive. Consequently, a multi-module system can produce high voltages and current, which constitute an increased hazard and could cause serious injury or death.

If modules are connected in parallel, then each module (or series string of modules so connected) shall be provided with the maximum series fuse as specified.

For roof mounting, the assembly is to be mounted over a fire-resistant roof covering rated for the application



MSX MODULE INSTALLATION USER MANUAL

VERSION: 1

VERSION DATE: 6/10/2025

DOCUMENT #: P-UM-0014

PAGE: 4 OF 15

3.1 GENERAL SAFETY

Follow All Permit, Installation, and Inspection Requirements

Before installing a module, contact appropriate authorities to determine permit, installation, and inspection requirements that should be followed. This should be done not only for installations in conjunction with buildings, but also for marine and motor vehicle applications for which additional requirements may apply.

Electrical ground module(s) for all systems of any voltage.

If not otherwise specified, it is recommended that the latest National and International Electrical Code requirements be followed.

For roof-mounted modules, special construction may be required to help provide proper installation. When installing modules on any structure above ground avoid any possible falling safety hazards by following appropriate safety practice(s) and using required safety equipment. Both roof construction and module installation design have an effect on the fire resistance of the building. Improper installation may contribute to hazards in the event of fire. Additional devices such as ground fault, fuses, and disconnects may be required.

Do not use modules of different configurations in the same system.

Follow all safety precautions of other used components.

Underwriters Laboratory Listing Information. To satisfy the conditions of the UL Listing when installing the modules, be sure to:

1. **Conductor recommendations:** single conductor cable, type USE-2 (non-conduit), 8-14 AWG (2.5-10 mm²).
2. **Observe the requirements described by note** under Electrical Characteristics in the Specifications section of this Guide.
3. **Grounding** of the module frame is required. When ground wires greater than No. 10 AWG are required, the installer will need to provide suitable terminal connectors to interface with the No.10 binding screw provided with each module.
4. **Environment:** The module is suitable for operation in an environmental temperature range -40 °C to +40 °C (-40 °F to 104 °F) and up to 100% relative humidity.
5. **Wind/snow load:** 50 lbs/ft² tested with a 1.5x safety factor
6. **Recommended number of panels in series:** V System Maximum / (1.25 x highest VOC)
7. **Recommended number of strings/panels in parallel:** Fuse Rating / (1.25 x highest ISC)
8. **Maximum altitude:** 2000 m

MSX MODULE INSTALLATION USER MANUAL

VERSION: 1

VERSION DATE: 6/10/2025

DOCUMENT #: P-UM-0014

PAGE: 5 OF 15

4.0 WARNING AND NOTICES

- The word "module" as used in this Guide refers to one or more solar electric modules.
Avoid electrical hazards when installing, wiring, operating and maintaining the module.
A module generates DC electricity when exposed to sunlight or other light sources.
- It is recommended that the module remains packed in the box until time of installation.
- Provide suitable guards to prevent contact with 30 VDC or greater. As an added precaution, use properly insulated tools only.
- Never leave a module unsupported or unsecured. If a module should fall, the glass can break. A module with broken glass cannot be repaired and must not be used.
- It must be assured that other system components do not generate any hazard of any mechanical or electrical nature to the module.
- Module installation and operation should be performed by qualified personnel only. Children should not be allowed near the solar electric installation.
- If not otherwise specified, it is recommended that requirements of the latest local, national or regional electrical codes be followed.
- Use module for its intended function only. Follow all module manufacturers' instructions. Do not disassemble the module, or remove any part or label installed by the manufacturer. Do not treat the back of the module with paint or adhesives.
- Retain this instruction booklet for future reference.
- The modules have been evaluated by UL for a maximum positive or negative design loading of 50 lbs/ft² with a safety factor of 1.5x.
- The installation of Auxin Solar modules should conform to electrical regulation of various countries.



- Do not touch terminals while module is exposed to light or during installation.
- When installing or working with module or wiring, cover module face completely with opaque material to halt production of electricity.

MSX MODULE INSTALLATION USER MANUAL

VERSION: 1
VERSION DATE: 6/10/2025

DOCUMENT #: P-UM-0014
PAGE: 6 OF 15



- Work only under dry conditions, with a dry module and tools.



- Do not stand or step on module



- Do not drill holes into module frame, as it will void warranty.



- Do not drop module or allow objects to fall on module.



- Do not artificially concentrate sunlight on the Front and Back of the module.

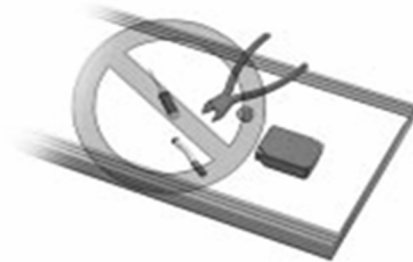

- Keep back surface free from foreign objects. Scratches or damage to back surface will void warranty.



- Mission Solar modules are comprised of a glass front surface, PET back sheet, and possess a Class C fire rating.



- Since sparks may be produced, do not install module where flammable gases or vapors are present.

MSX MODULE INSTALLATION USER MANUAL

VERSION: 1

VERSION DATE: 6/10/2025

DOCUMENT #: P-UM-0014

PAGE: 7 OF 15

5.0 INSTALLATION AND OPERATION

- Systems should be installed by qualified personnel only. The system involves electricity, and can be dangerous if the personnel are not familiar with the appropriate safety procedures.
- Do not step on the module.
- Although Mission Solar modules are quite rugged, the glass can be broken (and the module will no longer work properly) if it is dropped or hit by tools or other objects.
- Do not concentrate sunlight on the module.
- The module frame is made of anodized aluminum, and therefore corrosion can occur if the module is subject to a salt-water environment with contact to a rack of another type of metal. (Electrolysis Corrosion) If required, PVC or stainless-steel washers can be placed between the solar module frame and support structure to prevent this type of corrosion.
- Module support structures that are to be used to support Mission Solar module(s) should be wind rated and approved for use by the appropriate local and civil codes prior to installation.

The module is considered to be in compliance with this standard only when the module is mounted in the manner specified by the mounting instructions. A module with exposed conductive parts is considered to be in compliance with this standard only when it is electrically grounded in accordance with the manufacturer's instructions and the requirements of the National Electrical Code, ANSI/NFPA 70 (2014 2017).

5.1 MECHANICAL INSTALLATION

5.1.1 Using Mounting Holes

The aluminum frame of each module has 9 mm diameter mounting holes. These holes are used to fix the modules to the supporting structure. An example of a ground-mounted structure is shown as below.

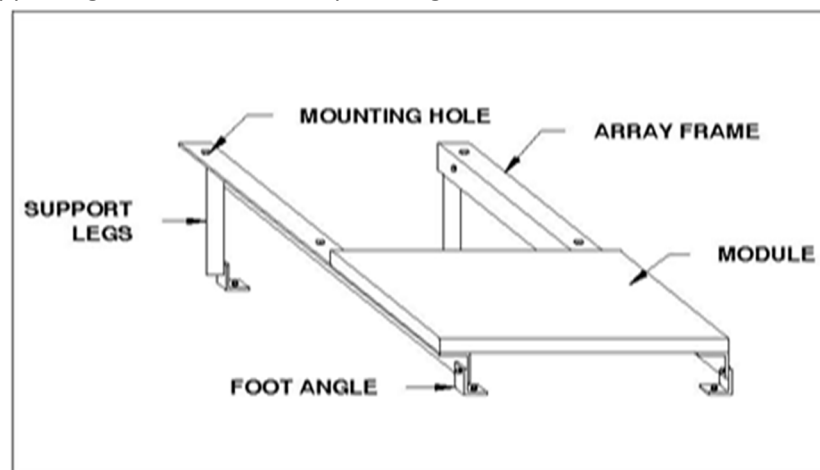

Insert one M9 (9 mm * L30 mm) stainless screw with M9 spring washer placed into each 7 mm diameter mounting hole (8 mounting holes in one module). Then use M9 nylon lock nuts to secure module on support structure. During securing, the torque force should be 6.5 foot-pounds or more.

MSX MODULE INSTALLATION USER MANUAL

VERSION: 1

VERSION DATE: 6/10/2025

DOCUMENT #: P-UM-0014

PAGE: 8 OF 15

Refer to the frame schematics for the position of these holes.

If using one pair of mounting rails, use inner most holes.

For installations using mounting holes and exposed to high wind and/or snow load, panels larger than 108-cell should use 4 rails with an 8-point attach.

5.1.2 Using Mounting Clamps

Mission Solar panels have been tested using IRONRIDGE UFO clamps and XR Rail. Please follow installation instructions from IRONRIDGE.

https://files.ironridge.com/pitched-roof-mounting/resources/brochures/IronRidge_Flush_Mount_Installation_Manual.pdf

Mission Solar panels may also be mounted using UL 2703 SkyGrip from Skyline Solar. Please refer to www.skylineaz.com for installation instructions.

Allowable clamp locations shown below:

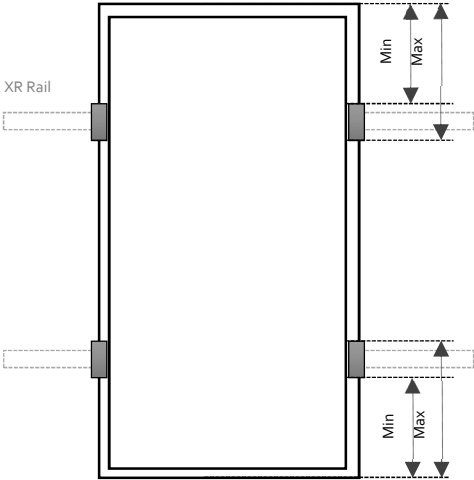

Module Size	Min	Max
1722 x 1134 mm	330	480
1908 x 1134 mm	340	545
2094 x 1134 mm	400	605
2278 x 1134 mm	439	644
1740 x 1134 mm	364	435
1928 x 1134 mm	385	482
2116 x 1134 mm	420	529
2302 x 1134 mm	440	575

Tighten clamps to 80 in-lbs.

5.2 ROOF MOUNT

Often the most convenient and appropriate place to put the PV array is on the roof of the building. The PV array may be mounted above and parallel to the roof surface with a **standoff of 6 inches** for cooling purposes. Sometimes, such as with flat roofs, a separate structure with a more optimal tilt angle is mounted on the roof. **A minimum slope of 5 in/ft (22.6 deg) for installation over a roof is required to maintain the fire class ratings.** Proper roof mounting can be labor intensive. Particular attention must be paid to the roof structure and the weather sealing of roof penetrations. It is typical to have one support bracket for every 100 Watts of PV modules. For new construction, support brackets are usually mounted after the roof decking is applied and before the roofing materials is installed. The crew in charge of laying out the array mounting system normally installs the

MSX MODULE INSTALLATION USER MANUAL

VERSION: 1

DOCUMENT #: P-UM-0014

VERSION DATE: 6/10/2025

PAGE: 9 OF 15

brackets. The roofing contractor can then flash around the brackets as they install the roof. A simple installation detail and a sample of the support bracket is often all that is needed for a roofing contractor to estimate the flashing cost. Masonry roofs are often structurally designed near the limit of their weight-bearing capacity. In this case, the roof structure must either be enhanced to handle the additional weight of the PV system or the masonry roof transitioned to composition shingles in the area where the PV array is to be mounted. By transitioning to a lighter roofing product, there is no need to reinforce the roof structure since the combined weight of composite shingles and PV array is usually less than the displaced masonry product.

5.3 FIRE RATING

Mission Solar modules are comprised of glass front surface and PET backsheet. **Fire rating: PV Type Designation 1.**

5.4 GROUNDING

Before installing your solar system, contact local authorities to determine the necessary grounding. Attach all module frames to an earth ground in accordance with the National Electrical Code (NEC). The grounding method of the frame of arrays shall comply with the NEC, Article 250. For CNL marked modules, the installation shall be in accordance with CSA C22.1, Safety Standard for Electrical Installations, Canadian Electrical Code, Part 1. CNL model instruction manuals shall be provided in French as well as in English. Proper grounding is achieved by connecting the module frame(s) and structural members contiguously one to another using a suitable "grounding conductor". Please use corrosion resistant hardware while grounding. Any hardware such as copper hardware which may cause corrosion or degradation of aluminum frame should be avoided. The grounding conductor, or strap, may be copper, copper alloy, or another material acceptable for use as an electrical conductor per NEC. The grounding conductor must then make a connection to earth using a suitable earth ground electrode. Ensure positive electrical contact through the anodizing on the module's frame by utilizing the following grounding method.

Use grounding holes in the PV module back flange to ground PV module.

Use solid uninsulated copper wire sizes 10 or 12 AWG as grounding conductor. The wire must not be nicked, cut, or scraped.

Install a grounding lug in one of the identified grounding holes on one module in each contiguous array. Use the grounding assembly by sliding the star washer on the steel bolt, inserting the bolt through the front of the grounding lug, sliding the spacer onto the bolt, inserting the bolt through the grounding hole on the module, and securing the bolt with the star washer/nut from the back side of the module. Torque the bolt to 60 inch-pounds. A solid gauge copper wire, AWG 4-10, is attached to this grounding lug. The copper wire is then connected to IlSCO, type GBL-4DB and torque to 20 in-lb for 10 to 12 AWG size wire, or 35 in-lb for 4 to 6 AWG size.

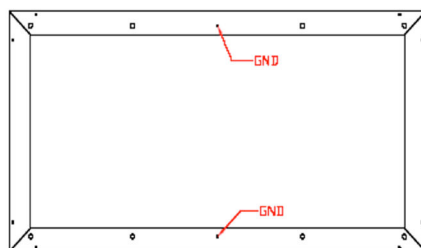

MSX MODULE INSTALLATION USER MANUAL

VERSION: 1

VERSION DATE: 6/10/2025

DOCUMENT #: P-UM-0014

PAGE: 10 OF 15

5.5 AIR CIRCULATION UNDER MODULE

Sufficient clearance between the module frame and the mounting surface is required to allow cooling air to circulate around the back of the module. This also allows any condensation or moisture to dissipate.

The module has been evaluated for use with a standoff height of 6 inches. A minimum slope of 5 in/ft (22.6 degrees) for installation over a roof is required to maintain the fire class ratings

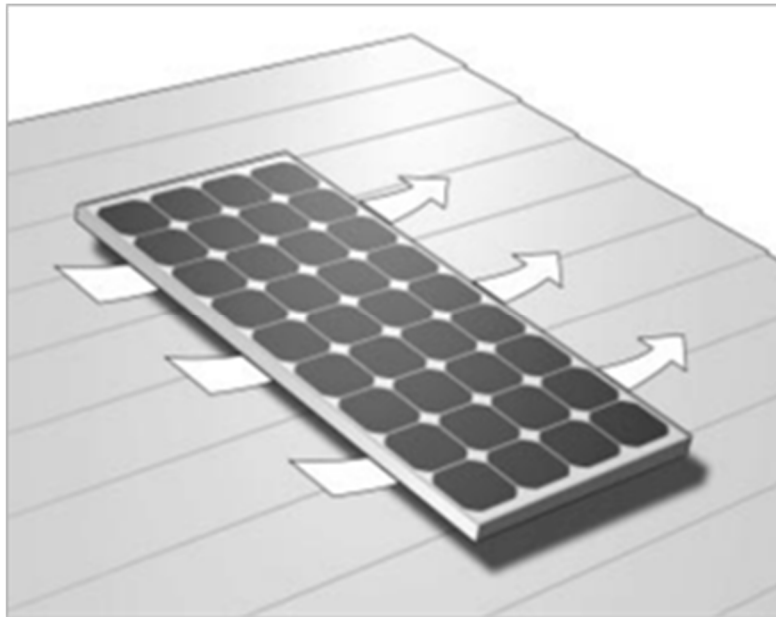

5.6 ELECTRICAL INSTALLATION

- Avoid all electrical hazards when installing, wiring, operating and maintaining a module.
- Do not use modules of different electrical or physical configurations in the same system.
- The maximum open circuit voltage of the system must not be greater than the specified maximum system voltage for the module.
- Module frames should be connected to an earth ground for safety and protection from lightning.
- All Mission Solar modules are equipped with factory-installed wires and quick connectors. Modules have been designed to be easily interconnected in series.
- Use system wiring with suitable cross-sectional areas and connectors that are approved for use at the maximum short-circuit current of the module.
- Match the polarities of cables and terminals when making the connections; failure to do so may result in damage to the module.
- When reverse currents can exceed the value of the maximum protective fuse marked on the back of the module, a properly rated and certified over current device (fuse or circuit breaker) must be connected in series with each module or string of modules.

MSX MODULE INSTALLATION USER MANUAL

VERSION: 1

VERSION DATE: 6/10/2025

DOCUMENT #: P-UM-0014

PAGE: 11 OF 15

- The rating of the over-current device shall not exceed the value of the maximum protective fuse marked on the back of the module.
- The module contains factory installed bypass diodes located inside the junction box.
- The junction box is not designed or certified to be field accessible or maintainable and should under no circumstances be opened. **Opening the junction box may void the warranty.**
- Modules with a suspected electrical problem should be returned to Mission Solar for inspection and possible repair or replacement as per the warranty conditions provided by Mission Solar.
- **Warning:** connecting modules in reverse polarity to a high current source, such as a battery, will destroy the bypass diodes and render the module inoperative. **Bypass diodes are not user replaceable.**

5.7 MODULES AND TERMINATION

7.6.1 RENHESOLAR RHC2xMzC (MC4 compatible) Plug Connector

x = s; z = C4

Attention: Do not disconnect under load!

Current path should only be disconnected using approved disconnect devices.

To protect against shock, ensure that conductors and their associated connectors are separated from opposite polarity components.

Connectors labeled with a + or – are keyed and can only be mated to similarly marked and keyed connectors.



5.7.2 RENHESOLAR RHC2xMzC (MC4 compatible) Plug Connector



CAUTION: Do not disconnect the connector under load!

MSX MODULE INSTALLATION USER MANUAL

VERSION: 1

VERSION DATE: 6/10/2025

DOCUMENT #: P-UM-0014

PAGE: 12 OF 15

Disconnect circuit from load before unplugging connectors.

Un-mating of the connector

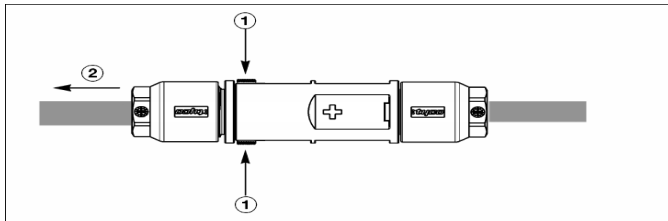

1. Depressing the latches as shown above opens the locking mechanism.
2. Pull out the connectors. While depressing the latches, disconnect the connector by pulling the connector halves apart.

Temperature Rating of conductor: -40 °C – +90 °C (-40 °F to 194 °F)

ATTENTION: Connectors must be fully mated to provide proper connection and protection against the elements.

6.0 MAINTENANCE, TESTING AND TROUBLESHOOTING

6.1 MAINTENANCE

Minimal maintenance is required to maintain optimal performance of your solar electric system.

If the front of the module becomes dirty, a reduction in energy output may result. We recommend the use of water and a soft cloth or sponge to clean the glass module surface. A mild non-abrasive detergent may be used if necessary.

Refer to the installation and operation manual of the other equipment including batteries and electronics for additional information.

6.2 SYSTEM TEST AND TROUBLESHOOTING

Systems have four key components, the solar modules, electronic devices (including the inverter and controller), batteries, and the system wiring. The most effective way to insure good system performance is to test the components in the system before it is turned on.

The system can include a single module or an array of modules in a series string and a parallel configuration.

To check the output of the solar modules:

Testing a Series String of Modules or Individual Module



Warning: When testing DC voltage over 30 VDC be sure to take all precautions to protect yourself against possible electric shock.



MSX MODULE INSTALLATION USER MANUAL

VERSION: 1

DOCUMENT #: P-UM-0014

VERSION DATE: 6/10/2025

PAGE: 13 OF 15

First, check the open circuit voltage of each series string of modules. The open circuit voltage per module is located in the Specifications section of this Guide. Test each series string by measuring this voltage at each pair of series string wires or terminals. Next, test the series string short circuit current at the same pair of series string wires or terminals. When testing short circuit current, each module must be exposed to bright sunlight. Refer to the Specifications section in this Guide to determine the current for the module under test. The current output will vary based on the time of day of the test, shading from obstructions, and the angle that the solar array is to the sun.

After these tests are complete, the array is ready to operate and can be connected to the rest of the system.



Caution! To help avoid shock hazard, cover module face completely (when not requiring sunlight for testing purposes) with opaque material to halt production of electricity.

Should the voltage reading be low, proceed to the next section, Low Voltage. Should the current be low, call Mission Solar customer service for warranty information.

Low Voltage

The two most common causes for low voltage are loose wiring connections and a short-circuited bypass diode.

To isolate the cause of low voltage, first check all wiring connections to insure good conductivity.

If all connections are secure, check the voltage of each module by removing a wire from the plus and minus terminals (to isolate the module from the rest of the series string) and test the module for voltage. A reading of ½ of the specified voltage indicates a short circuit of a bypass diode.

If the cause of low voltage is still undetermined, call Mission Solar customer service for warranty information.

7.0 SPECIFICATIONS

7.1 PHYSICAL SPECIFICATIONS

Model	# of cells	Pmax 'ppp'	L	W	H	Weight
MSX10-xxxHNOB	108	395-450	1722	1134	35	46.96 lbs



MSX MODULE INSTALLATION USER MANUAL

VERSION: 1

DOCUMENT #: P-UM-0014

VERSION DATE: 6/10/2025

PAGE: 14 OF 15

7.2 ELECTRICAL SPECIFICATIONS

Model #	VOC ±5%	VMP ±5%	Maximum System Voltage	IMP ±5%	ISC ±5%	Max Power ±5%	Maximum Series Fuse (A)
MSX10-395HN0B	37.03	31.00	1500	12.75	13.59	395	30
MSX10-400HN0B	37.20	31.17	1500	12.84	13.68	400	30
MSX10-405HN0B	37.36	31.36	1500	12.92	13.78	405	30
MSX10-410HN0B	37.54	31.55	1500	13.00	13.86	410	30
MSX10-415HN0B	39.30	33.04	1500	12.57	13.31	415	30
MSX10-420HN0B	39.36	33.11	1500	12.69	13.43	420	30
MSX10-425HN0B	39.42	33.17	1500	12.81	13.54	425	30
MSX10-430HN0B	39.48	33.23	1500	12.93	13.65	430	30
MSX10-435HN0B	39.56	33.31	1500	13.07	13.79	435	30
MSX10-440HN0B	39.62	33.37	1500	13.19	13.90	440	30
MSX10-445HN0B	39.68	33.44	1500	13.31	14.02	445	30
MSX10-450HN0B	39.75	33.51	1500	13.44	14.14	450	30

NOTE:

1. Rated electrical characteristics are within 10% of measure values at Standard Test Conditions (STC) of: 1000 W/m², 25 °C cell temperature and solar spectral irradiance per ASTM E 892.
2. Under normal conditions, a photovoltaic module may experience conditions that produce more current and voltage than reported at standard component test conditions. Accordingly, the values of ISC and VOC marked on UL Listed modules should be multiplied by a factor of 1.25 when determining voltage ratings, conductor capacities, fuse sizes, and size of controls connected to the module output. Refer to Section 690-8 of the US National Electrical Code for an additional multiplying factor of 1.25, which may be applicable.

7.3 TEMPERATURE COEFFICIENTS (per increase in °C)

Module series	ISC	VOC	POWER
MSX10-xxxHN0B	+0.04%	-0.28%	-0.38%

MSX MODULE INSTALLATION USER MANUAL

VERSION: 1

VERSION DATE: 6/10/2025

DOCUMENT #: P-UM-0014

PAGE: 15 OF 15

7.4 JUNCTION BOX SPECIFICATIONS

Renhesolar ZJRH – FT50xy AaGsg

7.5 BYPASS DIODE SPECIFICATIONS

Model Series	Junction box	Diode manufacturer	Diode type	Diode ratings	
				(A)	(PIV)
MSX10-xxxHN0B	FT50xy AaGsg	RENHESOLAR ZJRH	FMK4530T	30	45

7.5.1 Renhesolar Junction-box

7.6 FRAME SCHEMATICS

7.6.1 MSX10-xxxHN0B (108-cell)

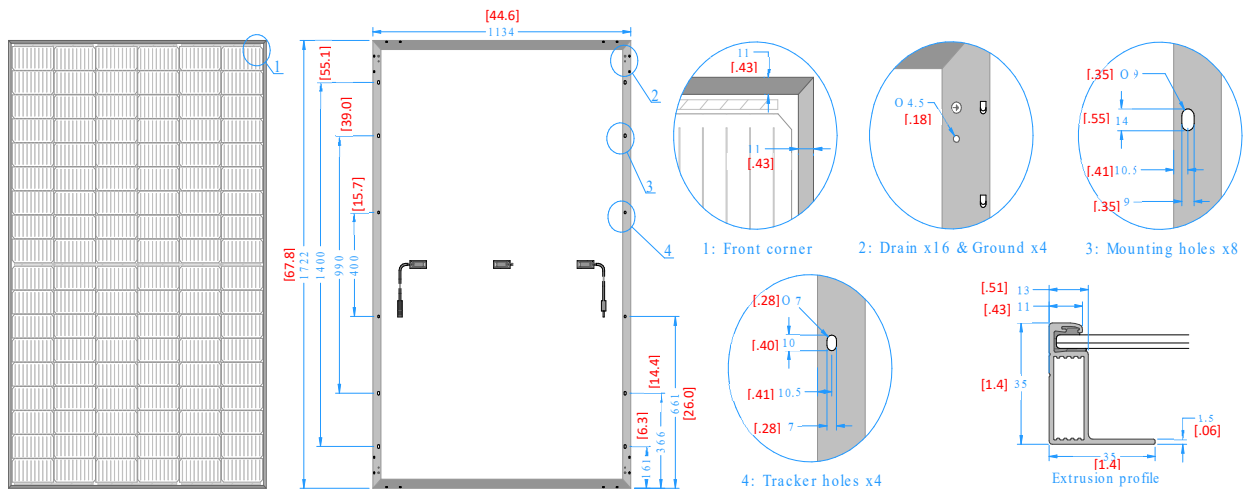

8.0 LIMITED WARRANTY

Mission Solar Energy PV modules come with limited workmanship and performance warranties. Please refer to the Mission Solar Energy PV Module Warranty document for details.